

A
B
C

SECTION RAX

REAR AXLE

RAX

CONTENTS

| | | | | |
|---|---|--|----|---|
| PRECAUTION | 2 | REAR WHEEL HUB AND HOUSING | 7 | F |
| PRECAUTIONS | 2 | Exploded View | 7 | |
| Precautions for Drive Shaft | 2 | Removal and Installation | 7 | |
| PREPARATION | 3 | Inspection | 8 | G |
| PREPARATION | 3 | REAR DRIVE SHAFT | 9 | |
| Commercial Service Tool | 3 | Exploded View | 9 | H |
| SYMPTOM DIAGNOSIS | 4 | Removal and Installation | 9 | |
| NOISE, VIBRATION AND HARSHNESS (NVH) TROUBLESHOOTING | 4 | WHEEL SIDE | 10 | |
| NVH Troubleshooting Chart | 4 | WHEEL SIDE : Disassembly and Assembly | 10 | I |
| PERIODIC MAINTENANCE | 5 | FINAL DRIVE SIDE | 12 | |
| REAR WHEEL HUB AND HOUSING | 5 | FINAL DRIVE SIDE : Disassembly and Assembly...12 | | |
| Inspection | 5 | Inspection | 14 | J |
| REAR DRIVE SHAFT | 6 | SERVICE DATA AND SPECIFICATIONS (SDS) | 16 | K |
| Inspection | 6 | SERVICE DATA AND SPECIFICATIONS (SDS) | 16 | |
| REMOVAL AND INSTALLATION | 7 | Wheel Bearing | 16 | L |
| | | Drive Shaft | 16 | |

E
F
G
H
I
J
K
L
M
N
O
P

PRECAUTIONS

< PRECAUTION >

PRECAUTION

PRECAUTIONS

Precautions for Drive Shaft

INFOID:000000007564329

- Observe the following precautions when disassembling and assembling drive shaft.
- Never disassemble joint sub-assembly because it is non-overhaul parts.
- Perform work in a location which is as dust-free as possible.
- Clean the parts, before disassembling and assembling.
- Prevent the entry of foreign objects during disassembly of the service location.
- Reassemble disassembled parts carefully in the correct order. If work is interrupted, a clean cover must be placed over parts.
- Use paper waste. Do not use fabric shop cloths because of the danger of lint adhering to parts.
- Clean disassembled parts (except for rubber parts) with kerosene which shall be removed by blowing with air or wiping with paper waste.

PREPARATION

< PREPARATION >

PREPARATION

PREPARATION

Commercial Service Tool

INFOID:000000007564330

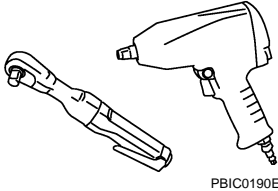
| Tool name | Description |
|--|--------------------------|
| Power tool  PBIC0190E | Loosening bolts and nuts |

A

B

C

RAX

E

F

G

H

I

J

K

L

M

N

O

P

REAR WHEEL HUB AND HOUSING

< PERIODIC MAINTENANCE >

PERIODIC MAINTENANCE

REAR WHEEL HUB AND HOUSING

Inspection

INFOID:000000007564332

MOUNTING INSPECTION

Make sure the mounting conditions (looseness, back lash) of each component and component conditions (wear, damage) are normal.

WHEEL BEARING INSPECTION

- Move wheel hub and bearing assembly in the axial direction by hand. Make sure there is no looseness of wheel bearing.

Standard

Axial end play : Refer to [RAX-16, "Wheel Bearing"](#).

- Rotate wheel hub and bearing assembly and make sure there is no unusual noise or other irregular conditions. If there is any of irregular conditions, replace wheel hub and bearing assembly.

A
B
C
RAX
E
F
G
H
I
J
K
L
M
N
O
P

REAR DRIVE SHAFT

< PERIODIC MAINTENANCE >

REAR DRIVE SHAFT

Inspection

INFOID:000000007564333

- Check drive shaft mounting point and joint for looseness and other damage.
- Check boot for cracks and other damage.

CAUTION:

Replace entire drive shaft assembly when noise or vibration occurs from drive shaft.

REAR WHEEL HUB AND HOUSING

< REMOVAL AND INSTALLATION >

REMOVAL AND INSTALLATION

REAR WHEEL HUB AND HOUSING

Exploded View

INFOID:000000007564334

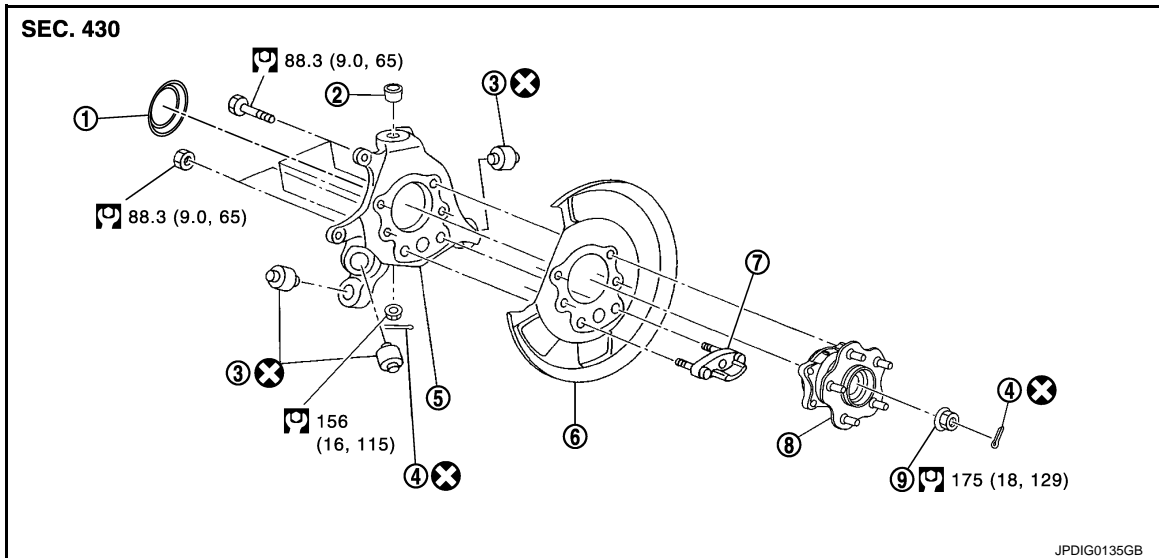

- | | | |
|-----------------|-----------------------------------|-----------------------|
| 1. Hub cap | 2. Ball seat | 3. Bushing |
| 4. Cotter pin | 5. Axle housing | 6. Back plate |
| 7. Anchor block | 8. Wheel hub and bearing assembly | 9. Wheel hub lock nut |

Refer to [GI-4, "Components"](#) for symbols in the figure.

Removal and Installation

INFOID:000000007564335

REMOVAL

1. Remove tires with power tool.
2. Remove wheel sensor and sensor harness. Refer to [BRC-99, "REAR WHEEL SENSOR : Exploded View"](#).
3. Remove caliper assembly. Hang caliper assembly not to interfere with work. Refer to [BR-40, "BRAKE CALIPER ASSEMBLY : Exploded View"](#).
CAUTION:
Never depress brake pedal while caliper assembly is removed.
4. Remove disc rotor. Refer to [BR-41, "BRAKE CALIPER ASSEMBLY : Removal and Installation"](#).
5. Remove cotter pin, then loosen suspension arm mounting nut of axle housing. Refer to [RSU-16, "Exploded View"](#).
6. Remove cotter pin, and then loosen wheel hub lock nut with power tool.
7. Patch wheel hub lock nut with a piece of wood. Hammer the wood to disengage wheel hub and bearing assembly from drive shaft. Remove the wheel hub lock nut.
CAUTION:
 - **Never place drive shaft joint at an extreme angle. Also be careful not to overextend slide joint.**
 - **Never allow drive shaft to hang down without support for housing (or joint sub-assembly), shaft and the other parts.**
- NOTE:**
Use suitable puller, if wheel hub and bearing assembly and drive shaft cannot be separated even after performing the above procedure.
8. Remove wheel hub and bearing assembly.
9. Remove parking brake shoe and parking brake cable from back plate. Refer to [PB-8, "Exploded View"](#) and [PB-6, "Exploded View"](#).

A
B
C
RAX
E
F
G
H
I
J
K
L
M
N
O
P

REAR WHEEL HUB AND HOUSING

< REMOVAL AND INSTALLATION >

10. Remove anchor block mounting nuts, and then remove anchor block and back plate from axle housing.
11. Remove stabilizer connecting rod (upper side) with power tool. Refer to [RSU-15, "Exploded View"](#).
12. Remove radius rod (axle housing side). Refer to [RSU-12, "Exploded View"](#).
13. Remove coil spring. Refer to [RSU-8, "Exploded View"](#).
14. Set suitable jack under axle housing.
15. Remove front lower link (shock absorber side) with power tool. Refer to [RSU-10, "Exploded View"](#).
16. Remove front lower link (axle housing side). Refer to [RSU-14, "Exploded View"](#).
17. Separate suspension arm from axle housing so as not to damage ball joint boot using ball joint remover, and then remove axle housing from the vehicle.

CAUTION:

- **Temporarily tighten nuts to prevent damage to threads and to prevent the ball joint remover from coming off.**
- **Never place drive shaft joint at an extreme angle. Also be careful not to overextend slide joint.**
- **Never allow drive shaft to hang down without support for counterpart such as joint sub-assembly, and other parts.**

INSTALLATION

Note the following, and install in the reverse order of removal.

- Never use a power tool to tighten the wheel hub lock nut.
- Perform the final tightening of each of parts under unladen conditions, which were removed when removing wheel hub and bearing assembly and axle housing.
- Never reuse cotter pin.

Inspection

INFOID:000000007564336

INSPECTION AFTER REMOVAL

Wheel Hub and Bearing Assembly

Check the wheel hub and bearing assembly for wear, cracks, and damage. Replace if necessary.

Axle Housing

Check the axle housing for wear, cracks, and damage. Replace if necessary.

Ball Joint Inspection

Check for boot breakage, axial looseness, and torque of suspension arm ball joint. Refer to [RSU-16, "Inspection"](#).

INSPECTION AFTER INSTALLATION

1. Check wheel sensor harness for proper connection. Refer to [BRC-99, "REAR WHEEL SENSOR : Exploded View"](#).
2. Adjust parking brake operation (stroke). Refer to [PB-3, "Inspection and Adjustment"](#).
3. Check wheel alignment. Refer to [RSU-6, "Inspection"](#).
4. Adjust neutral position of steering angle sensor. Refer to [BRC-31, "Work Procedure"](#).

REAR DRIVE SHAFT

< REMOVAL AND INSTALLATION >

REAR DRIVE SHAFT

Exploded View

INFOID:000000007564337

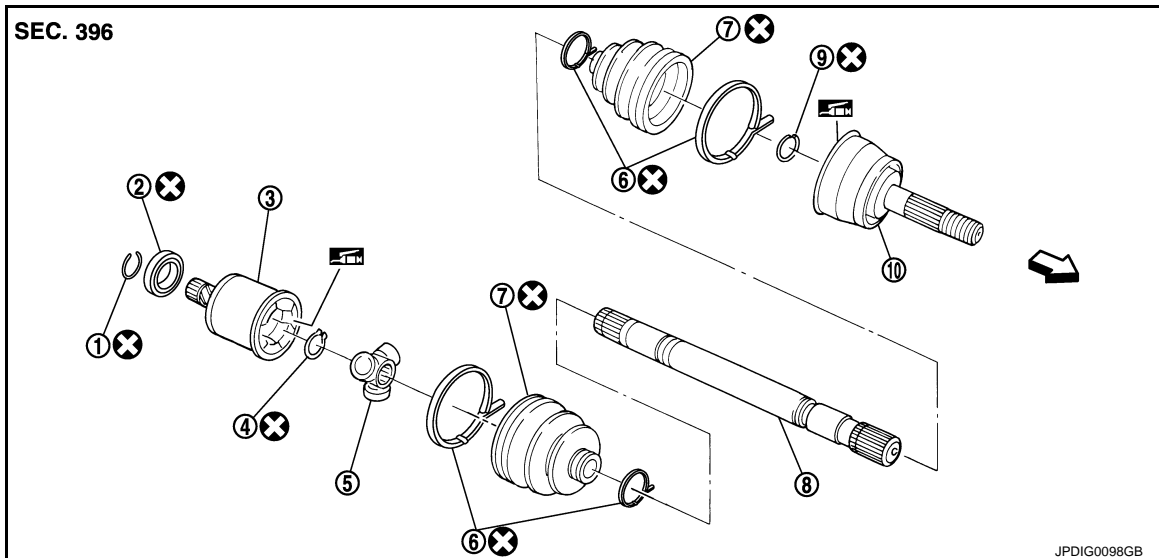

- | | | |
|------------------------|--------------------|------------------|
| 1. Circular clip | 2. Dust shield | 3. Housing |
| 4. Snap ring | 5. Spider assembly | 6. Boot band |
| 7. Boot | 8. Shaft | 9. Circular clip |
| 10. Joint sub-assembly | | |

⇐: Wheel side

: Fill NISSAN genuine grease or an equivalent.

Refer to [GI-4, "Components"](#) for symbols not described on the above.

Removal and Installation

INFOID:000000007564338

REMOVAL

1. Remove tires with power tool.
2. Remove wheel sensor and sensor harness. Refer to [BRC-99, "REAR WHEEL SENSOR : Exploded View"](#).
3. Remove caliper assembly. Hang caliper assembly not to interfere with work. Refer to [BR-40, "BRAKE CALIPER ASSEMBLY : Exploded View"](#).
- CAUTION:**
Never depress brake pedal while caliper assembly is removed.
4. Remove disc rotor. Refer to [BR-41, "BRAKE CALIPER ASSEMBLY : Removal and Installation"](#).
5. Remove cotter pin, then loosen wheel hub lock nut with power tool. Refer to [RAX-7, "Exploded View"](#).
6. Patch wheel hub lock nut with a piece of wood. Hammer the wood to disengage wheel hub and bearing assembly from drive shaft.

CAUTION:

- Never place drive shaft joint at an extreme angle. Also be careful not to overextend slide joint.
- Never allow drive shaft to hang down without support for housing (or joint sub-assembly), shaft and the other parts.

NOTE:

Use a suitable puller if the wheel hub and bearing assembly and drive shaft cannot be separated even after performing the above procedure.

7. Remove the wheel hub lock nut. Refer to [RAX-7, "Exploded View"](#).
8. Remove wheel hub and bearing assembly. Refer to [RAX-7, "Exploded View"](#).
9. Remove hub cap. Refer to [RAX-7, "Exploded View"](#).

REAR DRIVE SHAFT

< REMOVAL AND INSTALLATION >

10. Remove drive shaft from final drive assembly.

CAUTION:

Never damage to side oil seal of final drive.

INSTALLATION

Note the following, and install in the reverse order of removal.

- In order to prevent damage to final drive of side oil seal, first fit to protector (suitable tool) onto side oil seal before inserting drive shaft. Slide drive shaft into slide joint tap with a hammer to install securely.
- Never use a power tool to tighten the wheel hub lock nut.
- Perform the final tightening of each of parts under unladen conditions, which were removed when removing wheel hub and bearing assembly and axle housing.
- Never reuse cotter pin.

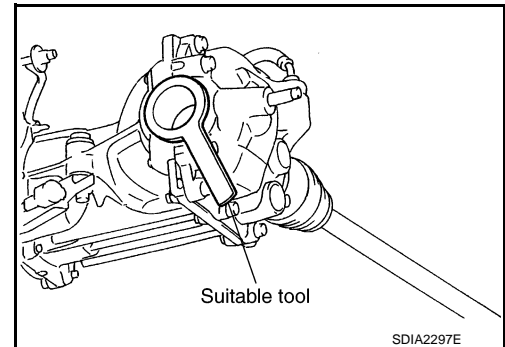

WHEEL SIDE

WHEEL SIDE : Disassembly and Assembly

INFOID:000000007564339

DISASSEMBLY

1. Fix shaft with a vise.

CAUTION:

Protect shaft when fixing with a vise using aluminum or copper plates.

2. Remove boot bands and then remove boot from joint sub-assembly.
3. Screw the drive shaft puller (A) 30 mm (1.18 in) or more into the thread of joint sub-assembly, and pull joint sub-assembly with a sliding hammer (B) from shaft.

CAUTION:

- If joint sub-assembly cannot be removed after five or more unsuccessful attempts, replace shaft and joint sub-assembly as a set.
- Align sliding hammer and drive shaft and remove them by pulling forcibly.

4. Remove circular clip from shaft.

CAUTION:

Never reuse circular clip.

5. Remove boot from shaft.

6. Clean old grease on joint sub-assembly with paper waste while rotating ball cage.

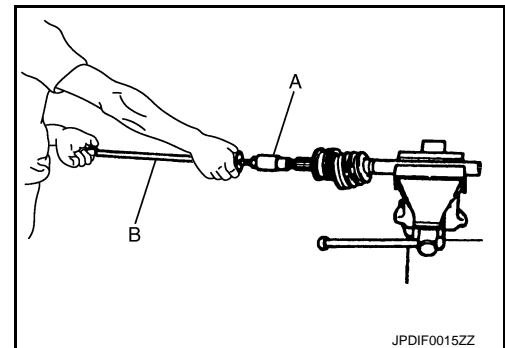

ASSEMBLY

1. Fill serration slot joint sub-assembly with NISSAN genuine grease or equivalent until the serration slot and ball groove become full to the brim.

CAUTION:

After applying grease, use a paper waste to wipe off old grease that has oozed out.

2. Install boot and boot band to shaft.

CAUTION:

- Wrap separation on shaft with tape to protect the boot from damage.
- Never reuse boot and boot band.

3. Remove the tape wrapped around the serration on shaft.

4. Position circular clip on groove at the shaft edge.

CAUTION:

Never reuse circular clip.

NOTE:

Drive joint inserter is recommended when installing circular clip.

5. Align both center axes of the shaft edge and joint sub-assembly. Then assemble shaft with joint sub-assembly holding circular clip.

REAR DRIVE SHAFT

< REMOVAL AND INSTALLATION >

6. Install joint sub-assembly to shaft using plastic hammer.

CAUTION:

Confirm that joint sub-assembly is correctly engaged while rotating drive shaft.

7. Apply the specified amount of grease into the boot inside from large diameter side of boot.

Standard

Grease amount : Refer to [RAX-16, "Drive Shaft"](#).

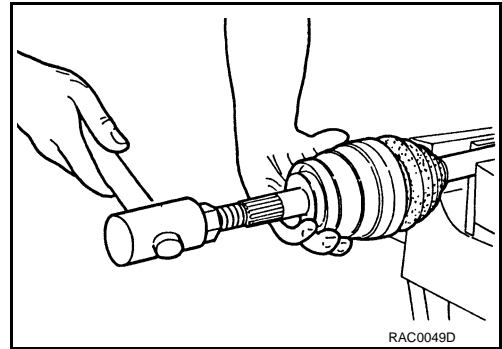

8. Install the boot securely into grooves (indicated by "*" marks) shown in the figure.

CAUTION:

If grease adheres to the boot mounting surface (indicated by "*" mark) on the shaft or joint sub-assembly, boot may be removed. Remove all grease from the boot mounting surfaces.

9. To prevent the deformation of the boot, adjust the boot installation length (L) to the specified value shown below by inserting the suitable tool into inside of the boot from the large diameter side of boot and discharging the inside air.

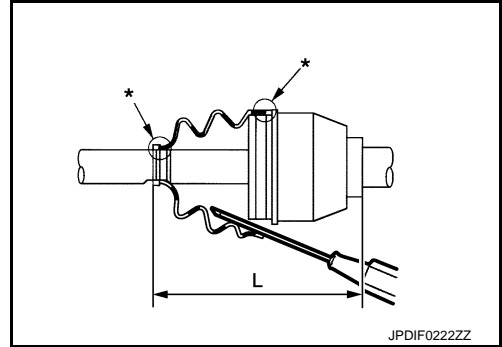

Standard

L : Refer to [RAX-16, "Drive Shaft"](#).

CAUTION:

- If the boot installation length exceeds the standard, it may cause breakage of boot.
- Be careful not to touch the inside of the boot with the tip of tool.

10. Install boot bands securely.

CAUTION:

Never reuse boot band.

- a. For one-touch clamp band
- Install boot bands securely as shown in the figure.

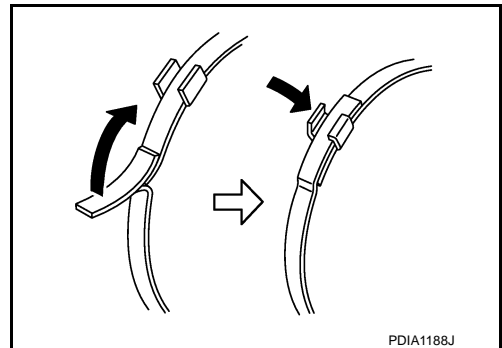

- b. For low profile type band

- i. Put boot band in the groove on drive shaft boot. Then fit pawls (←) into holes to temporary installation.

NOTE:

For the large diameter side, fit projection (A) and guide slit (B) at first.

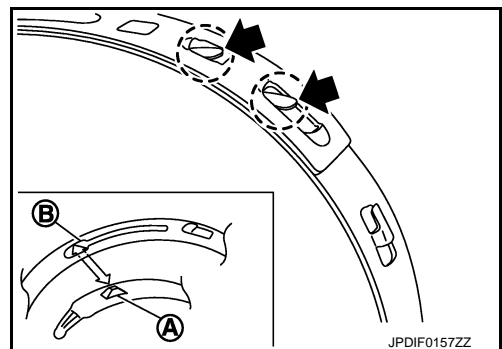

A
B
C
RAX
E
F
G
H
I
J
K
L
M
N
O
P

REAR DRIVE SHAFT

< REMOVAL AND INSTALLATION >

- ii. Pinch projection on the band with suitable pliers to tighten band.
- iii. Insert tip of band below end of the pawl.

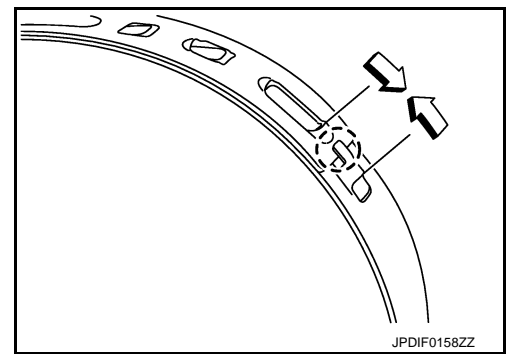

11. Secure joint sub-assembly and shaft, and then make sure that they are in the correct position when rotating boot. Install them with boot band when the mounting positions become incorrect.

CAUTION:

Never reuse boot band.

FINAL DRIVE SIDE

FINAL DRIVE SIDE : Disassembly and Assembly

INFOID:000000007564340

DISASSEMBLY

1. Fix shaft with a vise.

CAUTION:

Protect shaft when fixing with a vise using aluminum or copper plates.

2. Remove boot bands, and then remove boot from housing.
3. Put matching marks on housing and shaft, and then pull out housing from shaft.

CAUTION:

Use paint or an equivalent for matching marks. Never scratch the surface.

4. Put matching marks (A) on the spider assembly and shaft.

CAUTION:

Use paint or an equivalent for matching marks. Never scratch the surface.

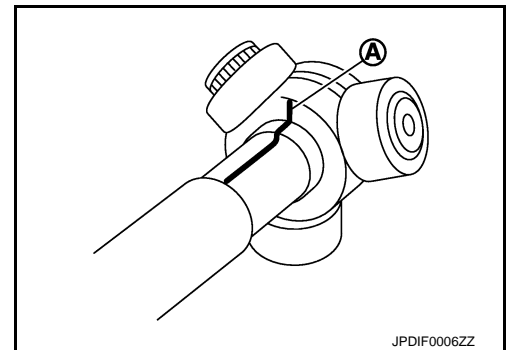

5. Remove snap ring (1), and then remove spider assembly from shaft.
6. Remove boot from shaft.
7. Remove circular clip housing.
8. Remove dust shield to housing.
9. Remove old grease on housing with paper waste.

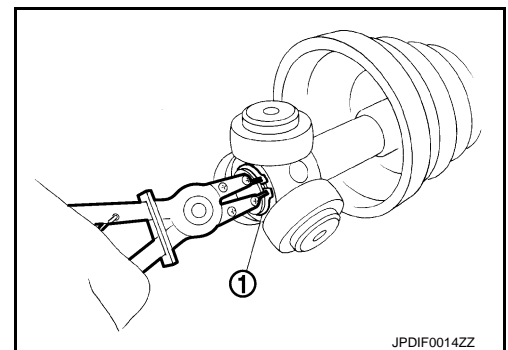

ASSEMBLY

1. Install boot and boot band to shaft.

CAUTION:

- **Wrap serration on shaft with tape to protect boot from damage.**
- **Never reuse boot and boot band.**

2. Remove the tape wrapped around the serration on shaft.

REAR DRIVE SHAFT

< REMOVAL AND INSTALLATION >

3. Install the spider assembly (1), align it with the matching marks (A) on the shaft (2) put during the removal, and direct the serration mounting surface (B) to the shaft.

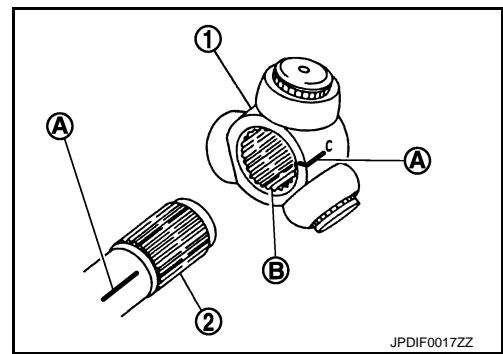

4. Secure spider assembly onto shaft with snap ring (1).
CAUTION:
Never reuse snap ring.
5. Apply the appropriate amount of grease onto housing and sliding surface.
6. Assemble the housing onto spider assembly, and apply the balance of the specified amount grease.

Standard

Grease amount : Refer to [RAX-16, "Drive Shaft"](#).

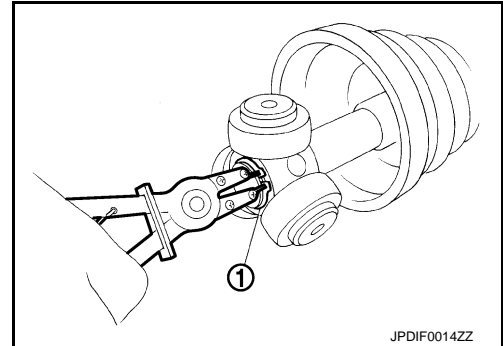

7. Align matching marks put during the removal of housing.
8. Install boot securely into grooves (indicated by "*" marks) shown in the figure.

CAUTION:

If grease adheres to the boot mounting surfaces (indicated by "*" marks) on shaft or housing, boot may be removed. Remove all grease from the boot mounting surfaces (*).

9. To prevent the deformation of the boot, adjust the boot installation length (L) to the value shown below by inserting the suitable tool into the inside of boot from the large diameter side of boot and discharging inside air.

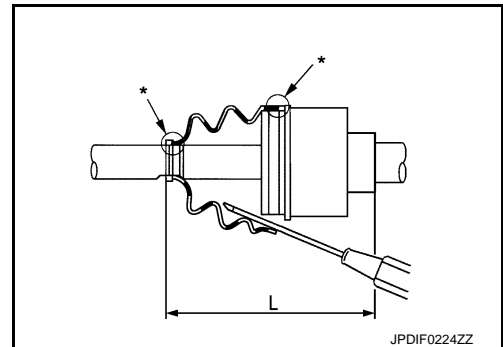

Standard

L : Refer to [RAX-16, "Drive Shaft"](#).

CAUTION:

- If the boot installation length exceeds the standard, it may cause breakage of boot.
- Be careful not to touch the inside of the boot with the tip of tool.

10. Install boot bands securely.

CAUTION:

Never reuse boot band.

- a. For one-touch clamp band
 - Install boot bands securely as shown in the figure.

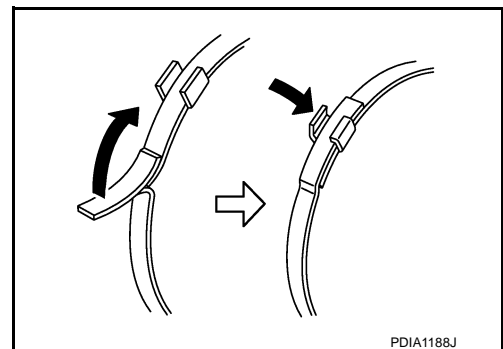

A
B
C
RAX
E
F
G
H
I
J
K
L
M
N
O
P

REAR DRIVE SHAFT

< REMOVAL AND INSTALLATION >

- b. For low profile type band
- i. Put boot band in the groove on drive shaft boot. Then fit pawls (←) into holes to temporary installation.

NOTE:

For the large diameter side, fit projection (A) and guide slit (B) at first.

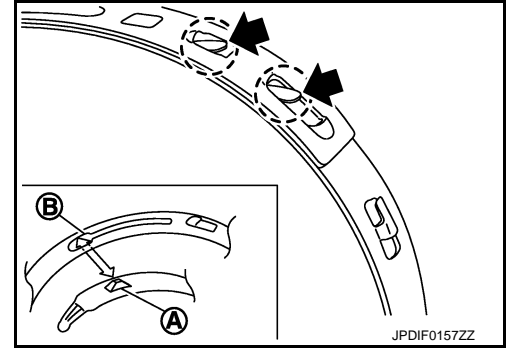

- ii. Pinch projection on the band with suitable pliers to tighten band.
- iii. Insert tip of band below end of the pawl.

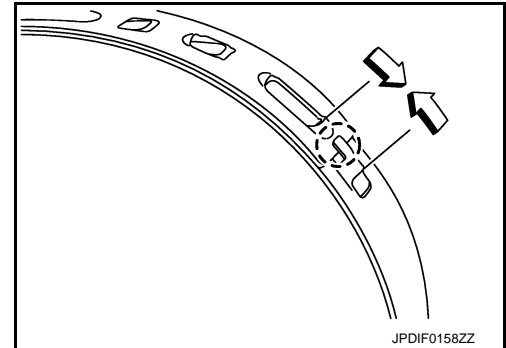

11. Secure housing and shaft, and then make sure that they are in the correct position when rotating boot. Install them with boot band when the mounting positions become incorrect.

CAUTION:

Never reuse boot band.

12. Install dust shield to housing.

CAUTION:

Never reuse dust shield.

13. Install circular clip to housing.

CAUTION:

Never reuse circular clip.

Inspection

INFOID:000000007564341

INSPECTION AFTER REMOVAL

- Move joint up/down, left/right, and in the axial direction. Check for any rough movement or significant looseness.
- Check boot for cracks or other damage, and also for grease leakage.
- If a malfunction is found, disassemble drive shaft, and then replace with new one.

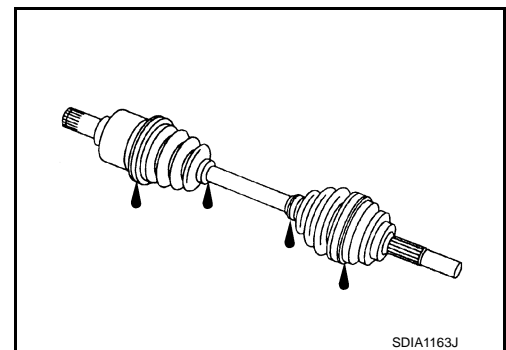

INSPECTION AFTER DISASSEMBLY

Shaft

Check shaft for runout, cracks, or other damage. Replace if there are any abnormal condition.

Joint Sub-Assembly (Wheel Side)

Check the following:

REAR DRIVE SHAFT

< REMOVAL AND INSTALLATION >

- Joint sub-assembly for rough rotation and excessive axial looseness.
 - The inside of the joint sub-assembly for entry of foreign material.
 - Joint sub-assembly for compression scars, cracks, and fractures inside of joint sub-assembly.
- Replace joint sub-assembly if there are any non-standard conditions of components.

Housing and Spider Assembly (Final Drive Side)

Replace housing and spider assembly if there is scratching or wear of housing roller contact surface or spider roller contact surface.

NOTE:

Housing and spider assembly are used in a set.

A

B

C

RAX

E

F

G

H

I

J

K

L

M

N

O

P

SERVICE DATA AND SPECIFICATIONS (SDS)

< SERVICE DATA AND SPECIFICATIONS (SDS)

SERVICE DATA AND SPECIFICATIONS (SDS)

SERVICE DATA AND SPECIFICATIONS (SDS)

Wheel Bearing

INFOID:000000007564342

| Item | Standard |
|----------------|----------------------------|
| Axial end play | 0.05 mm (0.002 in) or less |

Drive Shaft

INFOID:000000007564343

| Item | Standard | |
|------------------------|----------------------------|----------------------------|
| | Wheel side | Final drive side |
| Grease quantity | 30 – 50 g (1.06 – 1.76 oz) | 45 – 50 g (1.59 – 1.76 oz) |
| Boots installed length | 91.2 mm (3.591 in) | 126.9 mm (5.00 in) |